

MaxPulse P/N 9200-000-A/B
Installation and Operation Instructions

First:

Determine an appropriate location for the MaxPulse Control using the following guidelines:

- A) *The location must be within reach of the Pilot in Command while seated at the design eye position, without requiring excessive body movement.*
- B) *The location must be such that the pilot has an unobstructed view of the switch and is able to accurately determine switch positions with minimal head movement.*

Parts Supplied P/N 9200-000-A

- 1 ea MaxPulse Control P/N 9200-000-A, including STC logbook copy
- 1 ea Fully Insulated Red Female Crimp on Spade Connectors for 16-22 AWG Wire.
- 3 ea Fully Insulated Blue Female Crimp on Spade Connectors for 14-16 AWG Wire.
- 1 ea Panel Placard
- 1 ea Install Template
- 1 ea 1/16 in Long Handle Key Allen Wrench
- 1 ea Knob

Parts Supplied P/N 9200-000-B

- 1 ea MaxPulse Control P/N 9200-000-B, including STC logbook copy
- 1 ea Fully Insulated Red Female #6 Crimp on Ring Lug Connectors for 16-22 AWG Wire.
- 3 ea Fully Insulated Blue Female #6 Crimp on Ring Lug Connectors for 14-16 AWG Wire.
- 4 ea #6-32 X 1/4 Button Head Socket SS screws
- 4 ea #6 SS Internal Lock Washer
- 1 ea 1/16 in Long Handle Key Allen Wrench
- 1 ea 5/64 in Long Handle Key Allen Wrench
- 1 ea Panel Placard
- 1 ea Install Template
- 1 ea Knob

INSTALLATION 9200-000-A or B

1. Using the Template provided, drill two holes. Drill the first one (3/8") at the location where the center of the MaxPulse is desired. Drill the second (anti-rotation) hole (11/64"), offset to the right from the first 3/8" hole.
2. Determine the positive supply, lighting circuits, and chassis ground wiring locations, reference the Typical Wiring Diagrams located on page 3.
3. Test Position the MaxPulse Control and determine if any additional lengths of the wires are required.
4. Determine the current that the circuits will be required to carry.
5. Remove the MaxPulse Control and proceed with the installation. From the **WIRE SIZE-CURRENT CAPACITY TABLE**, select the wire size required. Use MIL-W-16878E/4 Type E, Mil-W-22759/16, Teflon insulated Copper Wire, or an equivalent.

Covers MaxPulse 9200-000-A and B

Document	Rev:	Date	Page
9150-001	G	6/22/2009	1 of 5

6. Install a 25 amp, maximum, Breaker between the power supply to the MaxPulse POS terminal. Calculate the optimum size using the formula on the wiring diagram.

MaxPulse 9200-000-A Wiring

1. Run a Red wire from the Breaker to the MaxPulse controller positive (POS) terminal, then install on the end of the red wire a Blue Female Solder-less Crimp Connector . Push the female connector onto the POS male connector on the MaxPulse controller.
2. Using the same technique that was used with the Red wire, run a Black wire from the GND male connector terminal on the MaxPulse to system ground or chassis ground. The common (Gnd) Wire is simply a signal wire used by the unit. It does not carry heavy currents during operation. Use a Red Female Solder-less Crimp Connector for this wire. Either color coded wires or labels may be used to identify the wires.
3. Again using the same technique that was used with the Red wire, run a Blue wire from output CKT1 to circuit #1. Select and install a Blue Female Solder-less Crimp Connector on the end of the Blue wire and push it onto the CKT1 male connector on the MaxPulse Controller. Duplicate this procedure Green wire for wiring CKT2 to circuit #2.

MaxPulse 9200-000-B Wiring

1. Again using the same technique that was used with the selection of the wire for the installation, instead of installing push on crimp connectors, install the crimp on ring lugs.
2. Each wire is connected to the MaxPulse with ring lugs crimped onto the wires and secured to the respective terminals on the MaxPulse with 6-32 X 1/4 Button Head Socket SS screws including the #6 external star lock washer.

MaxPulse 9200-000-B Connections No Drop Process

- Locate the 5/64 in Long Handle Key Allen Wrench
- Insert the Allen wrench into the head of the Button Head Screw.
- Place the #6 internal star lock washer onto the Button Head Screw.
- Place the Ring Lug with the crimped on wire onto the Button Head Screw.
- Screw the Button Head Screws into the threaded terminals on the MaxPulse

Installation Completion

1. With the MaxPulse Control inserted from the rear into the 3/8" drilled hole and with the reference label placed over the threads on the MaxPulse Control, install a washer and a nut to hold the MaxPulse Control in place.
2. Before tightening the nut, insure that the anti-rotation plastic bump is seated in the 11/64" hole and the panel label is aligned so that the most counter clock wise position of the switch lines up with the 'Off' position of the label.
3. Install the knob using the provided 1/16" hex key.
4. Since the original landing light switch is presently inoperable, it needs to be labeled with a placard; "INOP".

Typical Single Landing Light Switch Wiring Diagram

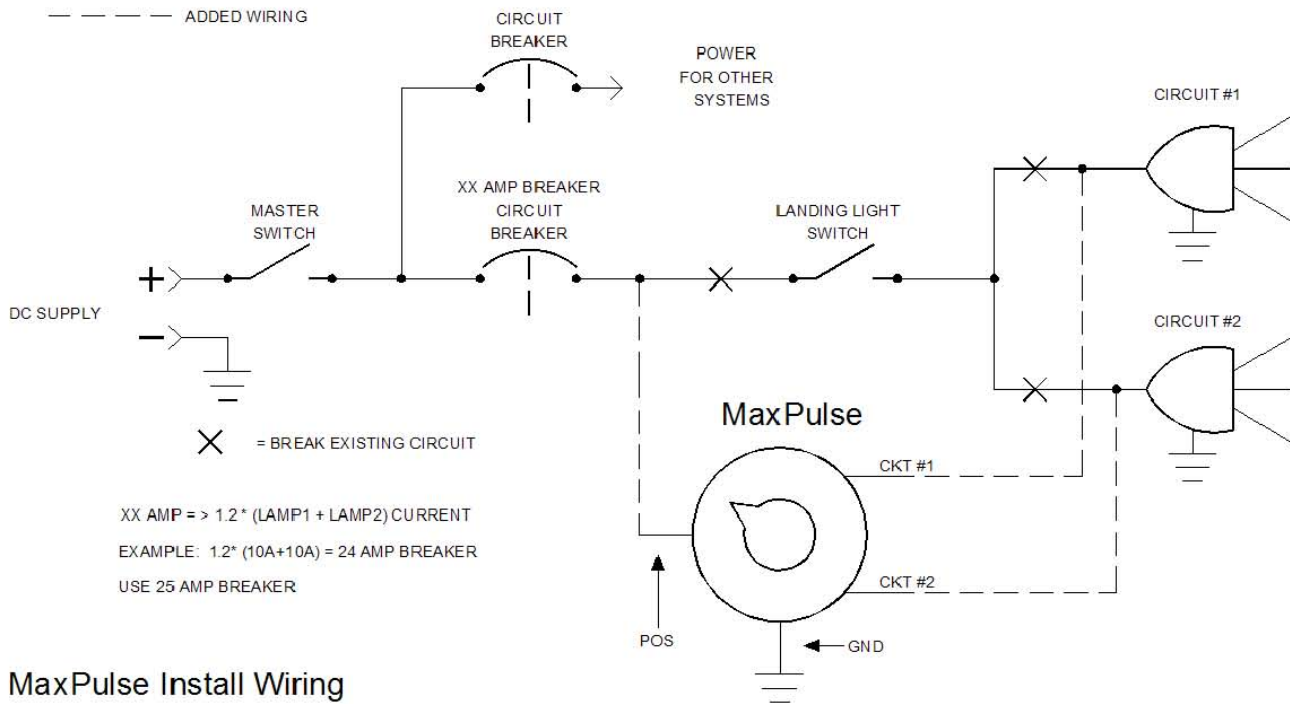

MaxPulse Install Wiring

Typical Dual Landing Light Switch Wiring Diagram

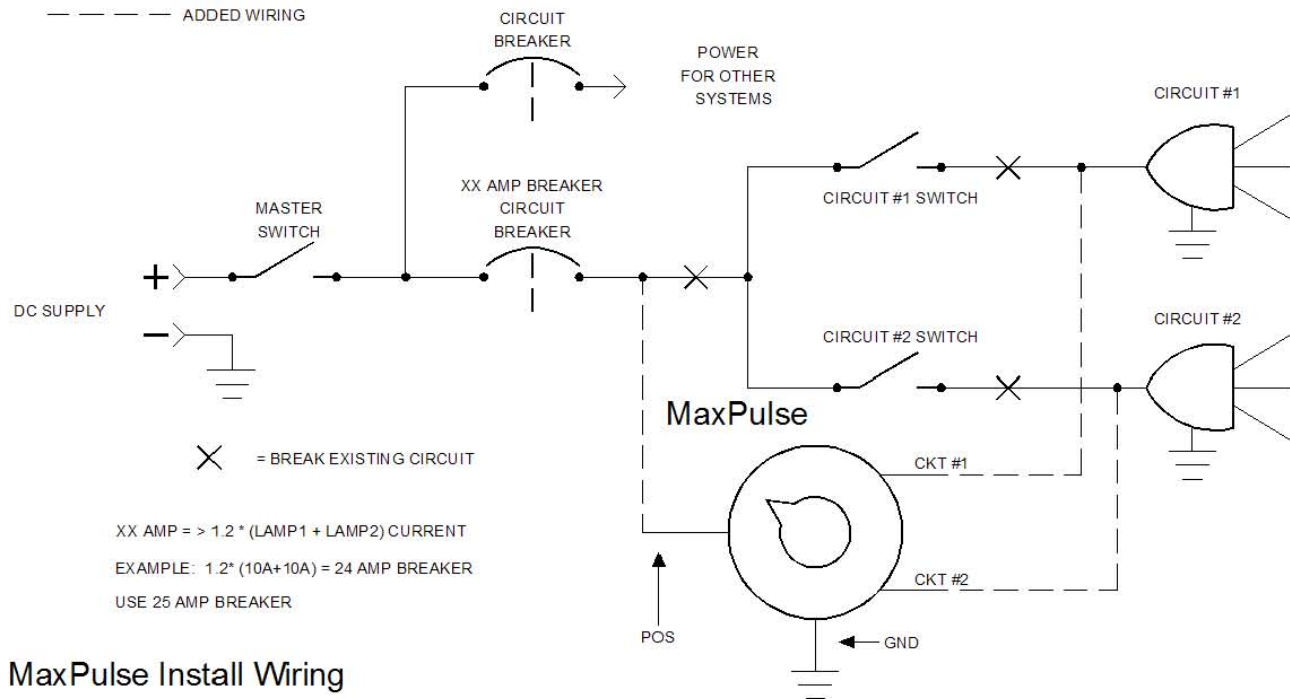

MaxPulse Install Wiring

AWG	Diameter	Diameter	Ohms Per	Ohms Per	Maximum	AWG	De-rated Current	
Gauge	Inches	mm	1000 Ft	km	Ampere	Gauge	Single	Bundled
14	0.0641	1.6281	2.525	8.282	32	14	19.0	8.5
15	0.0571	1.4503	3.184	10.4435	28	15	16.6	7.4
16	0.0508	1.2903	4.016	13.1725	22	16	13.0	6.5
17	0.0453	1.1506	5.064	16.6099	19	17	11.2	5.6
18	0.0403	1.0236	6.385	20.9428	16	18	9.2	5.0
19	0.0359	0.9119	8.051	26.4073	14	19	8.1	4.4
20	0.032	0.8128	10.15	33.292	11	20	6.5	3.7
21	0.0285	0.7239	12.8	41.984	9	21	5.3	3.0
22	0.0254	0.6452	16.14	52.9392	7	22	4.5	2.5

After completion of the installation, perform a functional test in accordance to the instructions found in the Instructions for Continued Airworthiness, document number 9150-008.

***Please check website at WWW.SEATONENG.COM
for the latest revision of these instructions***

FAA REQUIREMENTS

Amend the weight and balance records and make the necessary log book entry. Complete an FAA form 337 showing the installation of this equipment in accordance with the STC instruction and submit one copy to the FAA and one copy to the aircraft owner. File all data and a copy of the STC with the aircraft records.

ON YEAR LIMITED WARRANTY

SEC will repair or replace, at its expense and at its option any device manufactured by SEC which in the normal use has proven to be defective in workmanship or material, provided that the customer returns the product prepaid to SEC along with proof of purchase of the product within one year and provides SEC with reasonable opportunity to verify the alleged defect by inspection. SEC will not be responsible for any asserted defect which has resulted from misuse, abuse or over stressing above the published specifications. SEC will under no circumstances be liable for incidental or consequential damages resulting from the defective products. This warranty is SEC's Sole warranty and sets forth the customer's exclusive remedy, with respect to defective products; all other warranties, express or implied, whether of merchantability, fitness for purpose, or otherwise, are expressly disclaimed by SEC.

Seaton Engineering Corporation Spokane Valley, WA

MaxPulse Physical/Electrical/Operational Specifications

Voltage Range: 12 to 35VDC
Max Current: 10 A Per Circuit
Capacity Per Circuit:
 120 Watts @ 12 VDC
 240Watts @ 24 VDC
 280 Watts @ 28 VDC

Operating Temperature Range: -20°C to +50 °C
Internal Temperature Protect: +85 °C
Storage Temperature: -40°C to +100°C
Maximum Internal Temperature: @20 A +15 °C above Ambient.

Enclosure Material: Bayer FR110 Resin Meets UL 94
 Flame Rating: V-2 (0.03in) V-0 (0.059in) 5VB (0.098in)
 5VA (0.13in)

MaxPulse Eight Function Modes:

X = Both Circuits OFF
S = Starboard Circuit On
P = Port Circuit On
P+S = Port and Starboard Circuits On
A44 = Alternate P & S 44 Times/Minute
B44 = Both P & S on & off 44 Times/Minute
A88 = Alternate P & S 88 Times/Minute
A120 = Alternate P & S 120 Times/Minute

APPROVALS

FAA PMA STC SA01861SE

RTCA/DO160E Qualified

Ordering:

MaxPulse P/N 9200-000-A Spade Terminals

MaxPulse P/N 9200-000-B Screw Terminals

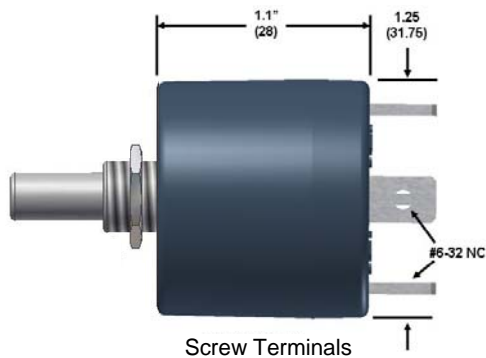

Screw Terminals

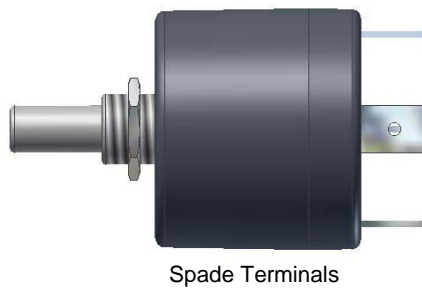

Spade Terminals

Weight: 1 oz (28g)



Covers MaxPulse 9200-000-A and B

Document	Rev:	Date	Page
9150-001	G	6/22/2009	5 of 5